



Analysis and Modeling of Magnetic Coupling

Bryce Hesterman
Advanced Energy Industries

Tuesday, 10 April 2007
Discovery Learning Center
University Of Colorado, Boulder, Colorado

Denver Chapter, IEEE Power Electronics Society
www.denverpels.org

Analysis and Modeling of Magnetic Coupling

**Denver Chapter of IEEE PELS
Discovery Learning Center
University of Colorado
April 10, 2007**

**Bryce Hesterman
Member of Technical Staff I
Advanced Energy Industries, Inc.
Fort Collins, Colorado**

bryce@ieee.org



Presentation Outline

- Introduction
- Modeling magnetic coupling with electric circuit equations
- Measuring electric circuit model parameters
- Equivalent circuits for transformers and coupled inductors
- Magnetic circuit modeling overview
- Tips for creating magnetic circuit models
- Deriving electric model parameters from magnetic model parameters
- Matrix theory requirements for coupling stability
- Examples



Motivation For This Presentation

- Magnetic coupling often seems to be mysterious and hard to quantify
- I had the good fortune of having a mentor, Dr. James H. Spreen, who taught me how to analyze magnetic coupling
- Goal: help make magnetic coupling less mysterious by showing how to model it, measure it and use it in circuit analysis and simulation



What Is Magnetic Coupling?

- Two windings are coupled when some of the magnetic flux produced by currents flowing in either of the windings passes through both windings
- Only part of the flux produced by a current in one winding reaches other windings

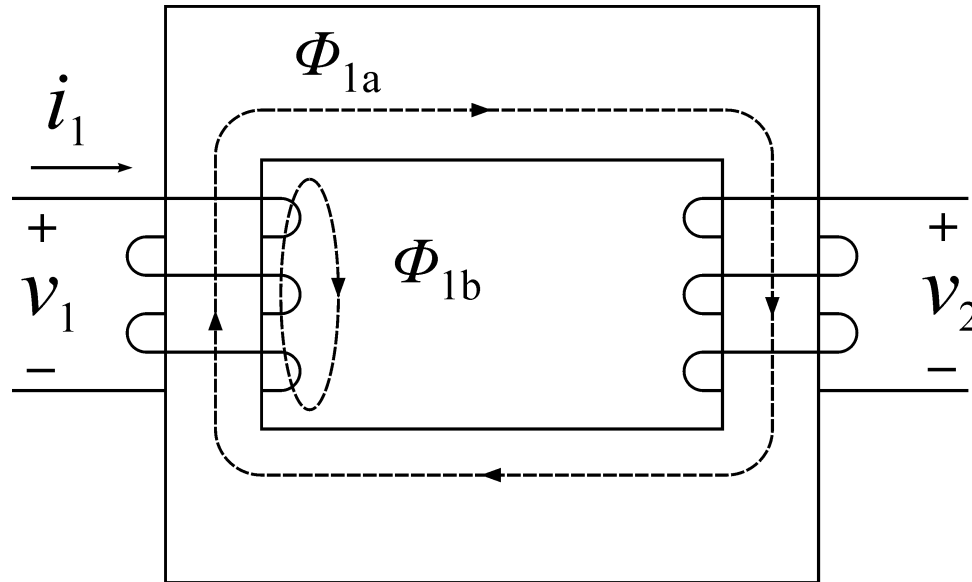

Magnetic Coupling Modeling Options

- Electric circuit: inductances and couplings
 - Linear model
 - Model parameters can be determined from circuit measurements
 - Parameters can be measured with fairly high accuracy if appropriate measurement procedures are followed
 - No information on flux paths or flux levels



Magnetic Coupling Modeling Options

- Magnetic circuit: reluctance circuit and electrical-to-magnetic interfaces for each winding
 - Explicitly shows flux paths as magnetic circuit elements
 - Flux paths and reluctances are only approximations
 - Works with linear or nonlinear reluctance models
 - Electrical circuit parameters can be calculated from magnetic circuit parameters, but not vice-versa



V-I Equations For an Isolated Inductor

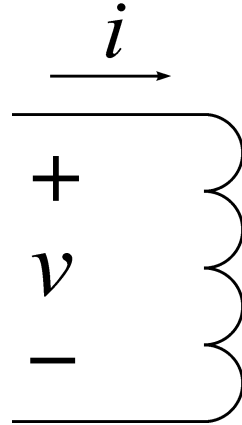

(Current flows into positive terminal)

Time domain

$$v = L \frac{di}{dt}$$

Frequency domain

$$v = j\omega Li$$



Time-domain Equations For Two windings

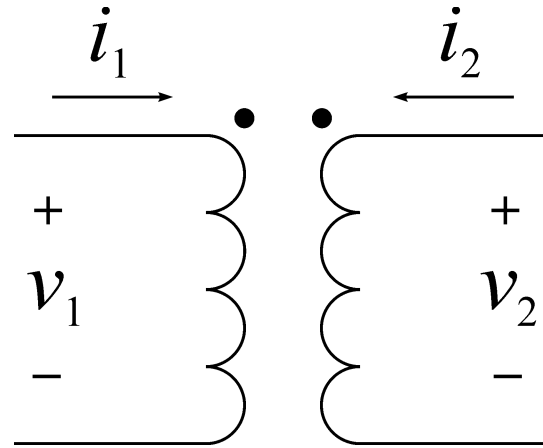

L_{11} = Self-inductance of winding 1

L_{22} = Self-inductance of winding 2

$L_{12} = L_{21}$ = Mutual inductance

$$v_1 = L_{11} \frac{di_1}{dt} + L_{12} \frac{di_2}{dt}$$

$$v_2 = L_{21} \frac{di_1}{dt} + L_{22} \frac{di_2}{dt}$$



Time-domain Equations For N Windings

$$v_1 = L_{11} \frac{di_1}{dt} + L_{12} \frac{di_2}{dt} + L_{13} \frac{di_3}{dt} + \dots + L_{1N} \frac{di_N}{dt}$$

$$v_2 = L_{21} \frac{di_1}{dt} + L_{22} \frac{di_2}{dt} + L_{23} \frac{di_3}{dt} + \dots + L_{2N} \frac{di_N}{dt}$$

$$\vdots$$

$$v_N = L_{N1} \frac{di_1}{dt} + L_{N2} \frac{di_2}{dt} + L_{N3} \frac{di_3}{dt} + \dots + L_{NN} \frac{di_N}{dt}$$

$$\begin{bmatrix} v_1 \\ v_2 \\ \vdots \\ v_N \end{bmatrix} = \begin{bmatrix} L_{11} & L_{12} & \cdots & L_{1N} \\ L_{21} & L_{22} & \cdots & L_{2N} \\ \vdots & \vdots & \ddots & \vdots \\ L_{N1} & L_{N2} & \cdots & L_{NN} \end{bmatrix} \frac{d}{dt} \begin{bmatrix} i_1 \\ i_2 \\ \vdots \\ i_N \end{bmatrix} \quad [v] = [L] \frac{d}{dt} [i]$$



Frequency-domain Equations For Two Windings

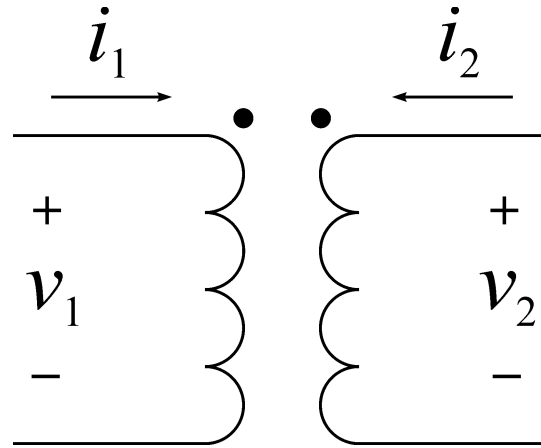

L_{11} = Self inductance of winding 1

L_{22} = Self inductance of winding 2

$L_{12} = L_{21}$ = Mutual inductance

$$v_1 = j\omega L_{11} i_1 + j\omega L_{12} i_2$$

$$v_2 = j\omega L_{21} i_1 + j\omega L_{22} i_2$$



Frequency-domain Equations For N Windings

$$v_1 = j\omega L_{11}i_1 + j\omega L_{12}i_2 + j\omega L_{13}i_3 + \dots + j\omega L_{1N}i_N$$

$$v_2 = j\omega L_{12}i_1 + j\omega L_{22}i_2 + j\omega L_{23}i_3 + \dots + j\omega L_{2N}i_N$$

$$\vdots$$

$$v_N = j\omega L_{N1}i_1 + j\omega L_{N2}i_2 + j\omega L_{N3}i_3 + \dots + j\omega L_{NN}i_N$$

$$\begin{bmatrix} v_1 \\ v_2 \\ \vdots \\ v_N \end{bmatrix} = j\omega \begin{bmatrix} L_{11} & L_{12} & \cdots & L_{1N} \\ L_{21} & L_{22} & \cdots & L_{2N} \\ \vdots & \vdots & \ddots & \vdots \\ L_{N1} & L_{N2} & \cdots & L_{NN} \end{bmatrix} \begin{bmatrix} i_1 \\ i_2 \\ \vdots \\ i_N \end{bmatrix} \quad [v] = j\omega [L][i]$$



Inductance Matrix Symmetry

- The inductance matrix is symmetric due to the reciprocity theorem (This is required for conservation of energy)

$$L_{qr} = L_{rq}$$

L. O. Chua, *Linear and Nonlinear Circuits*. New York: McGraw-Hill, 1987, pp. 771-780

- This principle can be derived from Maxwell's equations:

C. G. Montgomery, R. H. Dicke, and E. M. Purcell, Ed., *Principles of Microwave Circuits*. New York: Dover Publications, 1965

- It can also be derived from a stored energy argument:

R. R. Lawrence, *Principles of Alternating Currents*. New York: McGraw-Hill, 1935, pp. 187-188



Coupling Coefficient For Two Windings

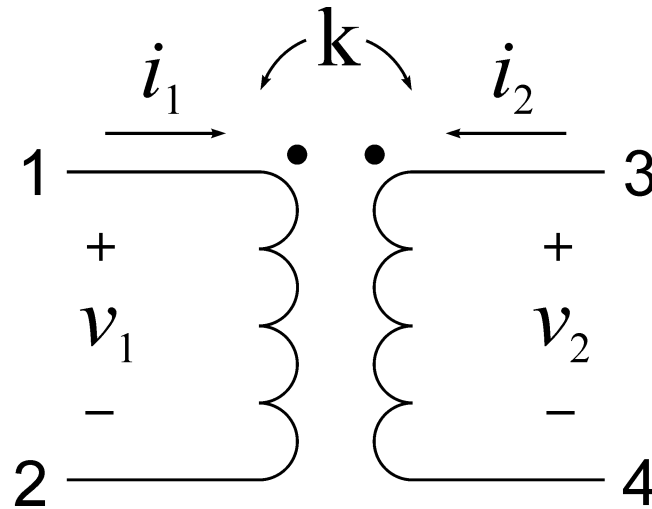

$$k = \frac{L_{12}}{\sqrt{L_{11}L_{22}}} = \frac{L_{21}}{\sqrt{L_{11}L_{22}}} = \frac{M}{\sqrt{L_1L_2}} \quad -1 \leq k \leq 1$$



Coupling Coefficients For N Windings

$$k_{qr} = \frac{L_{qr}}{\sqrt{L_{qq}L_{rr}}} \quad k_{qr} = k_{rq}$$

$$K = \begin{bmatrix} 1 & k_{12} & k_{13} \\ k_{21} & 1 & k_{23} \\ k_{31} & k_{32} & 1 \end{bmatrix} = \begin{bmatrix} 1 & \frac{L_{12}}{\sqrt{L_{11}L_{22}}} & \frac{L_{13}}{\sqrt{L_{11}L_{33}}} \\ \frac{L_{21}}{\sqrt{L_{22}L_{11}}} & 1 & \frac{L_{23}}{\sqrt{L_{22}L_{33}}} \\ \frac{L_{31}}{\sqrt{L_{33}L_{11}}} & \frac{L_{32}}{\sqrt{L_{33}L_{22}}} & 1 \end{bmatrix}$$



Coupling Measurement Techniques: Series-aiding Series-opposing Method

- Coupling measurements are made for each pair of windings
- Measure the inductance of each pair of windings connected in the series-aiding manner
- Measure the inductance of each pair of windings connected in the series-opposing manner

$$L_{12} = \frac{L_{aid} - L_{opp}}{4}$$

$$k = \frac{L_{12}}{\sqrt{L_1 L_2}} = \frac{L_{aid} - L_{opp}}{4\sqrt{L_1 L_2}}$$

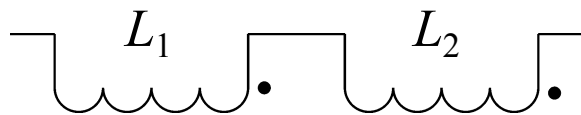

series-aiding, L_{aid}

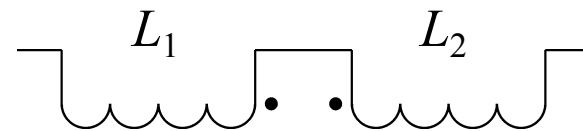

series-opposing, L_{opp}



Series-aiding Series-opposing Coupling Formula Derivation

- Start with the fundamental VI equations

$$v_1 = j\omega L_{11}i_1 + j\omega L_{12}i_2$$

$$v_2 = j\omega L_{12}i_1 + j\omega L_{22}i_2$$

$$-1 \leq k_{12} \leq 1$$

- Write down what is known for the series-aiding configuration

$$i_2 = i_1$$

$$v_{aid} = v_1 + v_2$$

$$v_{aid} = j\omega L_{aid}i_1$$

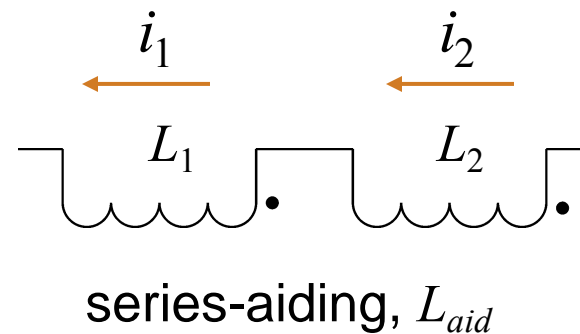

- Substitute assumptions for series aiding into V-I equations

$$v_1 = j\omega L_{11}i_1 + j\omega L_{12}i_1$$

$$v_2 = j\omega L_{21}i_1 + j\omega L_{22}i_1$$

- Recall $v_{aid} = v_1 + v_2$

- Substitute $v_{aid} = (j\omega L_{11}i_1 + j\omega L_{12}i_1) + (j\omega L_{12}i_1 + j\omega L_{22}i_1)$

- Simplify $v_{aid} = j\omega(L_{11} + 2L_{12} + L_{22})i_1$

- Recall $v_{aid} = j\omega L_{aid}i_1$

- Therefore $L_{aid} = L_{11} + 2L_{12} + L_{22}$



- Write down what is known for the series-opposing configuration

$$i_2 = -i_1$$

$$v_{opp} = v_1 - v_2$$

$$v_{opp} = j\omega L_{opp} i_1$$

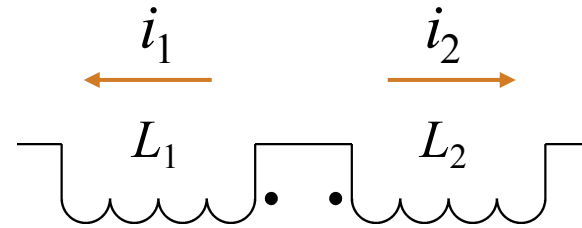

series-opposing, L_{opp}

- Substitute assumptions for series-opposing into V-I equations

$$v_1 = j\omega L_{11} i_1 - j\omega L_{12} i_1$$

$$v_2 = j\omega L_{21} i_1 - j\omega L_{22} i_1$$

- Recall $v_{opp} = v_1 - v_2$

- Substitute $v_{opp} = (j\omega L_{11} i_1 - j\omega L_{12} i_1) - (j\omega L_{12} i_1 - j\omega L_{22} i_1)$



- Simplify $v_{opp} = j\omega(L_{11} - 2L_{12} + L_{22})i_1$
- Recall $v_{opp} = j\omega L_{opp} i_1$
- Therefore $L_{opp} = L_{11} - 2L_{12} + L_{22}$
- Recall $L_{aid} = L_{11} + 2L_{12} + L_{22}$
- Subtract $L_{aid} - L_{opp} = 4L_{12}$
- Solve $L_{12} = \frac{L_{aid} - L_{opp}}{4}$
- Recall $k = \frac{L_{12}}{\sqrt{L_{11}L_{22}}}$
- Therefore $k = \frac{L_{aid} - L_{opp}}{4\sqrt{L_{11}L_{22}}}$



Coupling Measurement Techniques: Voltage Ratio Method

- Coupling measurements are made for each pair of windings
- Measure the voltage at each winding when a voltage is applied to the other winding

v_{ocqr} = voltage measured at winding q when winding r is driven

v_{drq} = voltage measured at winding r when winding r is driven and the voltage at winding q is being measured

$$k = \sqrt{\frac{v_{oc21} v_{oc12}}{v_{d12} v_{d21}}}$$

- Measurements can be corrupted by capacitance and loading
- Particularly suited for measurements between windings on different legs of three-phase ungapped transformers



Voltage Ratio Method

Coupling Formula Derivation

- Start with the fundamental VI equations

$$v_1 = j\omega L_{11} i_1 + j\omega L_{12} i_2$$

$$v_2 = j\omega L_{12} i_1 + j\omega L_{22} i_2$$

- Find i_1 and v_2 when winding 1 is driven and winding 2 is unloaded

$$v_1 = v_{d12} = j\omega L_{11} i_1 \longrightarrow i_1 = \frac{v_{d12}}{j\omega L_{11}}$$

$$v_2 = v_{oc21} = j\omega L_{12} i_1$$

- Substitute i_1 ,
simplify and
rearrange

$$v_{oc21} = j\omega L_{12} \frac{v_{d12}}{j\omega L_{11}} \longrightarrow \frac{v_{oc21}}{v_{d12}} = \frac{L_{12}}{L_{11}}$$



- Find i_2 and v_1 when winding 2 is driven and winding 1 is unloaded

$$v_2 = v_{d21} = j\omega L_{22}i_2 \longrightarrow i_2 = \frac{v_{d21}}{j\omega L_{22}}$$

$$v_1 = v_{oc12} = j\omega L_{12}i_2$$

- Substitute i_2 ,
simplify and
rearrange

$$v_{oc12} = j\omega L_{12} \frac{v_{d12}}{j\omega L_{22}} \longrightarrow \frac{v_{oc12}}{v_{d21}} = \frac{L_{12}}{L_{22}}$$

- Recall

$$\frac{v_{oc21}}{v_{d12}} = \frac{L_{12}}{L_{11}}$$

$$k = \sqrt{\frac{v_{oc21}}{v_{d12}} \frac{v_{oc12}}{v_{d21}}}$$

- Multiply

$$\frac{v_{oc21}}{v_{d12}} \frac{v_{oc12}}{v_{d21}} = \frac{L_{12}}{L_{11}} \frac{L_{12}}{L_{22}}$$



- Take the square root

$$\sqrt{\frac{v_{oc21}}{v_{d12}} \frac{v_{oc12}}{v_{d21}}} = \frac{L_{12}}{\sqrt{L_{11}L_{22}}} = k$$

- Therefore

$$k = \sqrt{\frac{v_{oc21}}{v_{d12}} \frac{v_{oc12}}{v_{d21}}}$$



Coupling Measurement Techniques: Self and Leakage Inductance Method

- Coupling measurements are made for each pair of windings
- Measure the self inductance of each winding (L_{11} and L_{22})
- The inductance measured at a winding when another winding is shorted is called the leakage inductance

L_{leakqr} = inductance measured at winding q when winding r is shorted

$$k_{12} = \sqrt{1 - \frac{L_{leak12}}{L_{11}}} \quad k_{21} = \sqrt{1 - \frac{L_{leak21}}{L_{22}}}$$

If perfect measurements are made, $k_{12} = k_{21}$



Self and Leakage Inductance Method Coupling Formula Derivation

- Start with the fundamental VI equations

$$v_1 = j\omega L_{11}i_1 + j\omega L_{12}i_2$$

$$v_2 = j\omega L_{12}i_1 + j\omega L_{22}i_2$$

- Find the leakage inductance at winding 1 when winding 2 is shorted, L_{12s}
Write down what is known for that condition

$$v_1 = j\omega L_{leak12}i_1$$

$$v_2 = 0 = j\omega L_{12}i_1 + j\omega L_{22}i_2$$

- Simplify

$$0 = L_{12}i_1 + L_{22}i_2$$



- Solve for i_2

$$i_2 = -i_1 \frac{L_{12}}{L_{22}}$$
- Combine equations for v_1

$$v_1 = j\omega L_{leak12} i_1 = j\omega L_{11} i_1 + j\omega L_{12} i_2$$
- Simplify
$$L_{leak12} i_1 = L_{11} i_1 + L_{12} i_2$$
- Substitute value of i_2

$$L_{leak12} = L_{11} - \frac{L_{12}^2}{L_{22}}$$



- Divide by L_{11}

$$\frac{L_{leak12}}{L_{11}} = 1 - \frac{L_{12}^2}{L_{11}L_{22}}$$

- Rearrange

$$1 - \frac{L_{12s}}{L_{11}} = \frac{L_{12}^2}{L_{11}L_{22}}$$

- Take square root

$$\sqrt{1 - \frac{L_{leak12}}{L_{11}}} = \frac{L_{12}}{\sqrt{L_{11}L_{22}}}$$

- Therefore

$$k = \sqrt{1 - \frac{L_{leak12}}{L_{11}}}$$

- Similar formula when winding 1 is shorted

$$k = \sqrt{1 - \frac{L_{leak21}}{L_{22}}}$$



Self Inductance Measurement Tips

- The ratios of the self inductances of windings on the same core will be nearly equal to the square of the turns ratios
- The ratios of the inductances are more important than the exact values
- Measure at a frequency where the Q is high
(It doesn't have to be at the operating frequency)
- Avoid measuring inductance close to self-resonant frequencies
- Take all measurements at the same frequency



Self Inductance Measurement Tips

For ungapped cores:

- The ratios of the inductances are more important than the exact values
- Inductance measurements may vary with amplitude of the test signal
- Best results are obtained if the core excitation is equal for all measurements
- If possible, adjust the measurement drive voltage to be proportional to the turns in order to keep the flux density constant
- Inductance measurements can be made at flux levels near normal operating levels using a power amplifier and a network analyzer



Leakage Inductance Measurement Tips

- Avoid measuring inductance close to self-resonant frequencies
- Winding resistances decrease the measured coupling coefficients when using the self and leakage inductance method
- Measure at a frequency where the Q is high
(It doesn't have to be at the operating frequency)
- For each pair of windings, shorting the winding with the highest Q gives the best results.



Coupling Coefficient Value Discrepancies

- Use the same value for k_{12} and k_{21} when performing circuit calculations
- If $k_{12} \neq k_{21}$, the one with the largest value is usually the most accurate



Coupling Coefficient Significant Digits

- Inductances can typically be measured to at least two significant figures
- Use enough significant digits for coupling coefficients in calculations and simulations to be able to accurately reproduce the leakage inductance

$$k = \sqrt{1 - \frac{L_{leak12}}{L_{11}}} \quad \longleftrightarrow \quad L_{leak12} = L_{11} (1 - k_{12}^2)$$

- Generally use at least four significant digits when the coupling coefficient is close to 1 (k is known to more significant digits than the measured inductances it was derived from)



Coupling Polarity Conventions

- Polarity dots indicate that all windings which have dots of the same style will have matching voltage polarities between the dotted and un-dotted terminals when one winding is driven and all of the other windings are open-circuited
- By convention, positive current flows into the terminals that are labeled as being positive regardless of the polarity dot positions
- Voltage reference polarities can be assigned in whatever manner is convenient by changing the polarity of the coupling coefficient

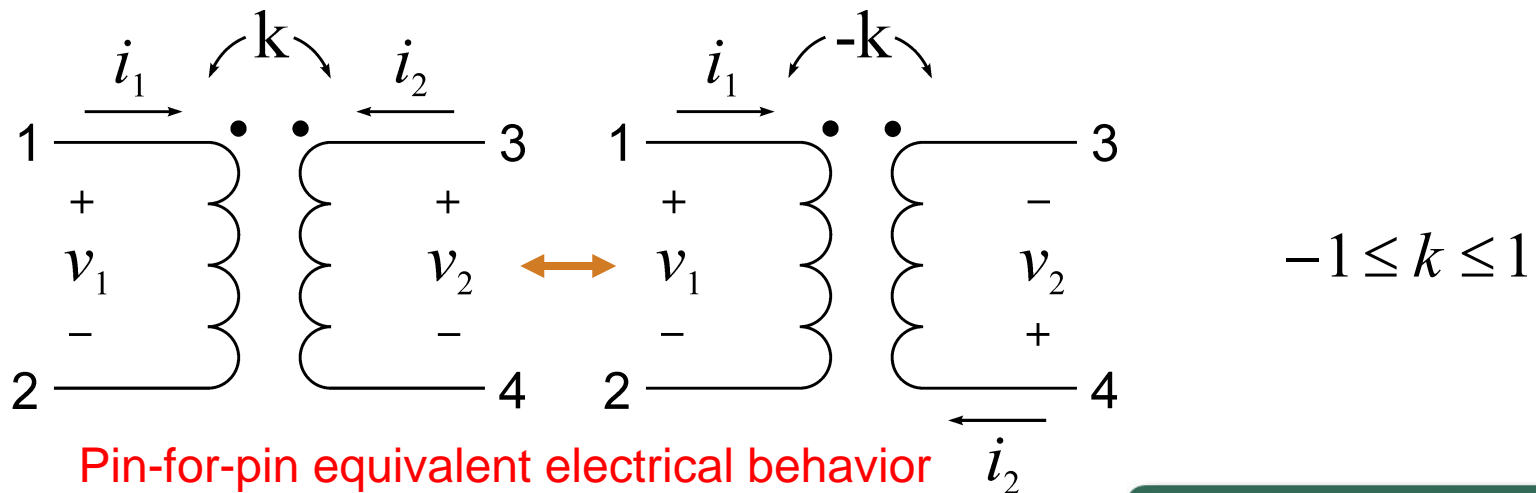

Three-legged Transformer Coupling Coefficient Dot Convention

- Three types of polarity dots are required for a three-legged transformer
- There are three coupling coefficients
- The triple product of the three coupling coefficients is negative
- It is simplest to make all three of the coupling coefficients negative

$$k_{12}k_{23}k_{31} \leq 0$$

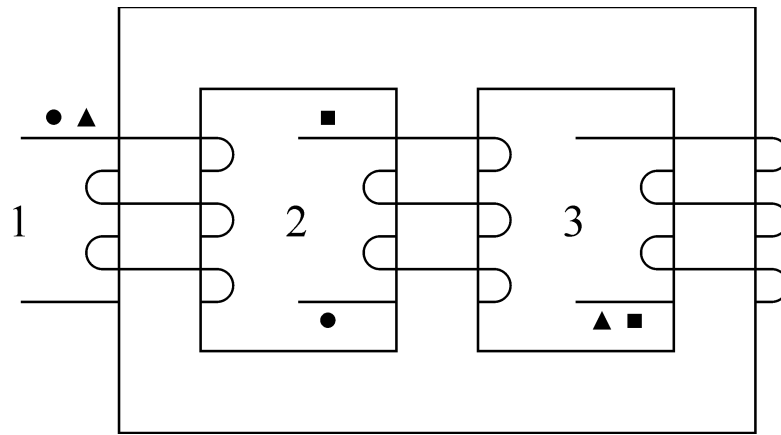

Equivalent Circuits For Two Windings

- Many possible circuits, but only three parameters are required
- My favorite is the Cantilever model: two inductors and one ideal transformer

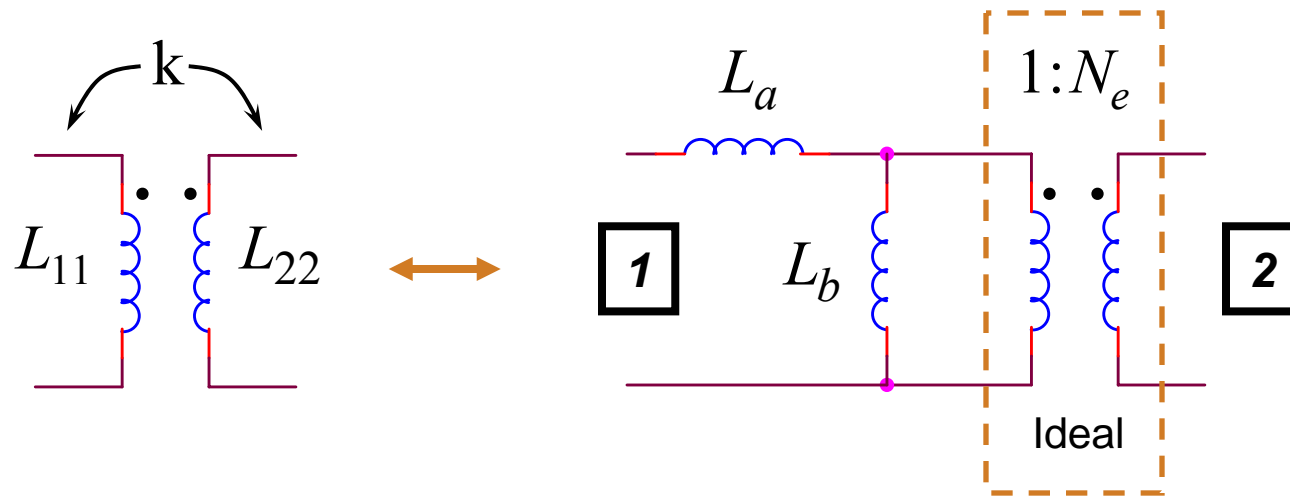

$$L_a = L_{leak12}$$

$$L_b = L_{11} - L_a$$

$$N_e = \sqrt{\frac{L_{22}}{L_b}}$$

Measure the inductance at winding 1 with winding 2 shorted

Measure the self inductance of winding 1 and subtract L_a

Measure the self inductance of winding 2 and calculate above equation



Cantilever Model Derivation

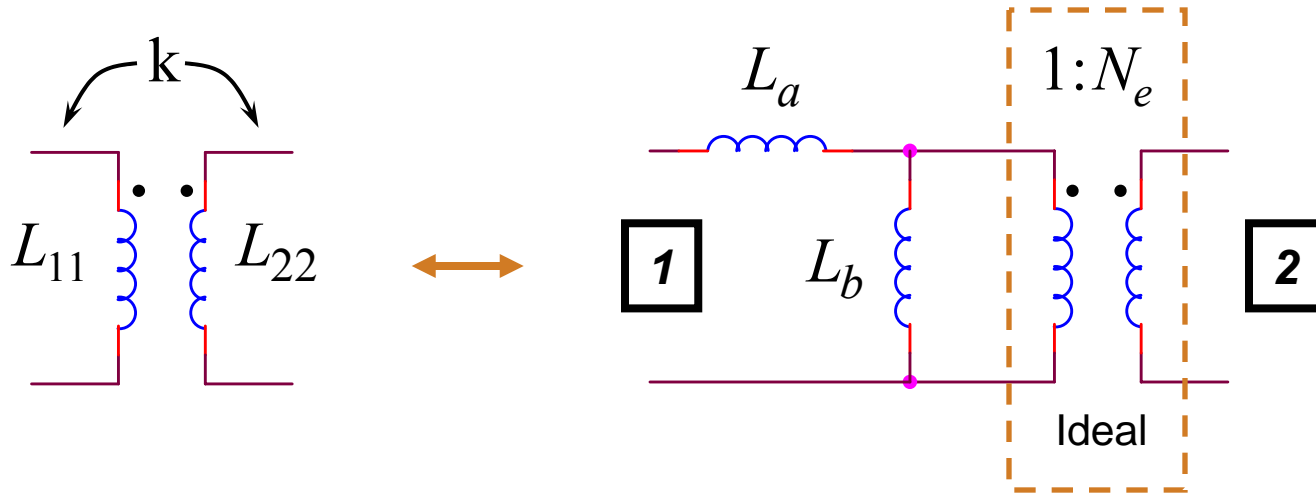

- If winding 2 is shorted, then the inductance measured at winding 1 is simply L_a because the ideal transformer shorts out L_b . Thus L_a is equal to the leakage inductance measured at winding 1.

$$L_a = L_{leak12}$$

- To convert the coupled inductor model to the cantilever model, recall that

$$L_{leak12} = L_{11}(1 - k^2)$$

- Therefore $L_a = L_{11}(1 - k^2)$



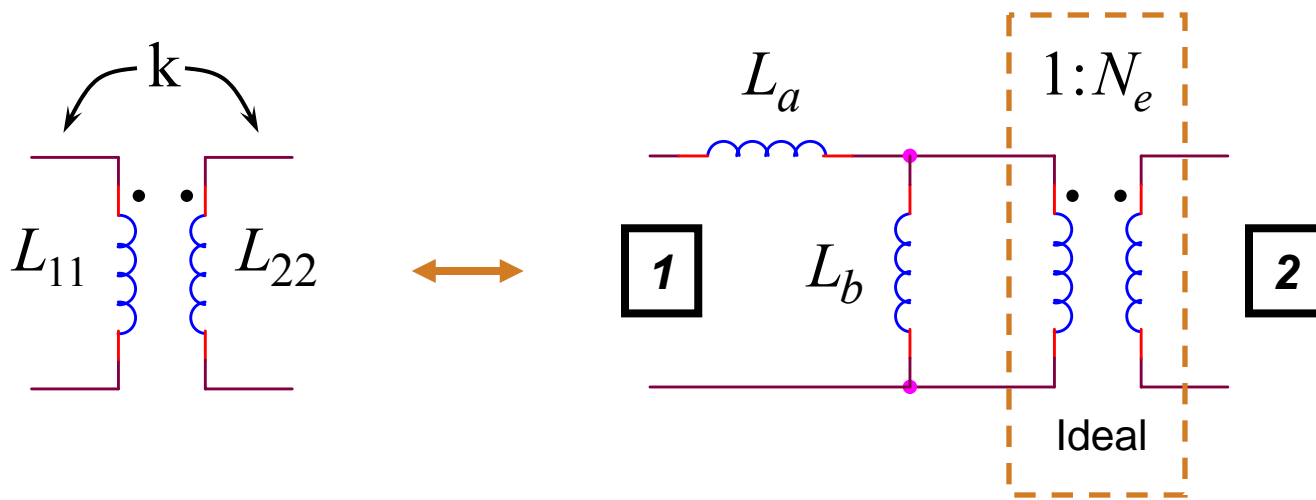

- By observation, L_b must equal the open-circuit inductance of winding 1 minus L_a

$$L_b = L_{11} - L_a$$

- To convert the coupled inductor model to the cantilever model, recall that

$$L_a = L_{11}(1 - k^2)$$

- Substitute

$$L_b = L_{11} - L_{11}(1 - k^2)$$

- Therefore

$$L_b = k^2 L_{11}$$



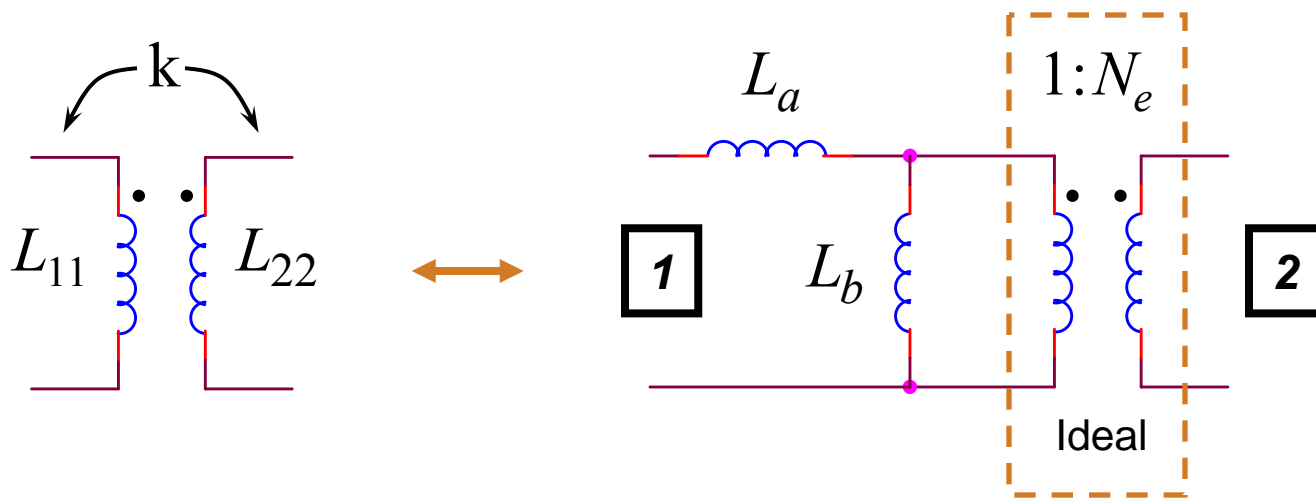

- The inductance of winding 2, L_{22} , is equal to L_b reflected through the ideal transformer

$$L_{22} = N_e^2 L_b$$

- Solve for the turns ratio

$$N_e = \sqrt{\frac{L_{22}}{L_b}}$$

- Recall $L_b = k^2 L_{11}$

- Thus, in terms of the coupled inductor model

$$N_e = \frac{1}{k} \sqrt{\frac{L_{22}}{L_{11}}}$$



Two Leakage Inductance Model

- Two Leakage Inductance model allows the actual turns ratio to be used, but it adds unnecessary complexity
- These “leakage inductances” are not equal to the previously-defined conventional leakage inductances measured by shorting windings

$$L_{11} = L_{l1} + L_{Mag}$$

$$L_{22} = L_{l2} + L_{Mag} \left(\frac{N_2}{N_1} \right)^2$$

$$L_{12} = L_{Mag} \left(\frac{N_2}{N_1} \right) \quad k = \frac{L_{12}}{\sqrt{L_{11}L_{22}}}$$

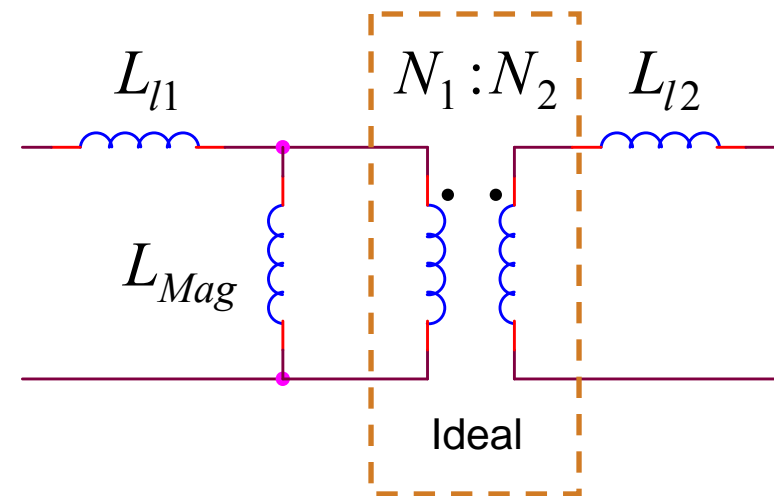

$$L_{Mag} = \left(\frac{N_1}{N_2} \right) \sqrt{L_{11}L_{22} - L_{leak12}L_{22}} = \left(\frac{N_1}{N_2} \right) \sqrt{L_{11}L_{22} - L_{leak21}L_{11}}$$



Two Leakage Inductance Model Derivation

- Start with the fundamental VI equations

$$v_1 = j\omega L_{11}i_1 + j\omega L_{12}i_2$$

$$v_2 = j\omega L_{12}i_1 + j\omega L_{22}i_2$$

- Write down the open-circuit primary voltage due to a current in the secondary

$$v_1 = j\omega L_{12}i_2 = j\omega L_{Mag} \left(\frac{N_2}{N_1} \right) i_2$$

- By inspection, the mutual inductance is

$$L_{12} = L_{Mag} \left(\frac{N_2}{N_1} \right)$$



- Solve for L_{Mag}
$$L_{Mag} = \left(\frac{N_1}{N_2} \right) L_{12}$$

- Recall
$$L_{11} = L_{l1} + L_{Mag} \quad L_{22} = L_{l2} + L_{Mag} \left(\frac{N_2}{N_1} \right)^2$$

- Solve for the two “leakage inductances”

$$L_{l1} = L_{11} - L_{Mag} \quad L_{l2} = L_{22} - L_{Mag} \left(\frac{N_2}{N_1} \right)^2$$

- Recall the equation for L_{leak12} from the derivation of the Self and Leakage Inductance model

$$L_{leak12} = L_{11} - \frac{L_{12}^2}{L_{22}}$$

- By symmetry,

$$L_{leak21} = L_{22} - \frac{L_{12}^2}{L_{11}}$$



- Solve for L_{12}

$$L_{12} = \sqrt{L_{11}L_{22} - L_{leak12}L_{22}} = \sqrt{L_{11}L_{22} - L_{leak21}L_{11}}$$

- Recall

$$L_{Mag} = \left(\frac{N_1}{N_2} \right) L_{12}$$

- Therefore

$$L_{Mag} = \left(\frac{N_1}{N_2} \right) \sqrt{L_{11}L_{22} - L_{leak12}L_{22}}$$

- Also,

$$L_{Mag} = \left(\frac{N_1}{N_2} \right) \sqrt{L_{11}L_{22} - L_{leak21}L_{11}}$$



Equivalent Circuits For More Than Two Windings

- Many possible circuits, but only $N(N+1)/2$ parameters are required
- My favorite is the extended cantilever model
 - Exact correspondence to the coupling coefficient model
 - R. W. Erickson and D. Maksimovic, "A multiple-winding magnetics model having directly measurable parameters," in *Proc. IEEE Power Electronics Specialists Conf.*, May 1998, pp. 1472-1478
- Extended cantilever model with parasitics:

K. D. T. Ngo, S. Srinivas, and P. Nakmahachalasint, "Broadband extended cantilever model for multi-winding magnetics," *IEEE Trans. Power Electron.*, vol. 16, pp. 551-557, July 2001

K.D.T. Ngo and A. Gangupomu, "Improved method to extract the short-circuit parameters of the BECM," *Power Electronics Letters, IEEE*, vol.1, no.1, pp. 17- 18, March 2003



Winding Self Inductance

- Replace the MMF source for each winding not being considered with a short circuit
- Determine the Thévenin equivalent reluctance, \mathcal{R}_{th} , at the MMF source representing the winding for which the self inductance is being calculated
- Inductance = turns squared divided by the Thévenin equivalent reluctance

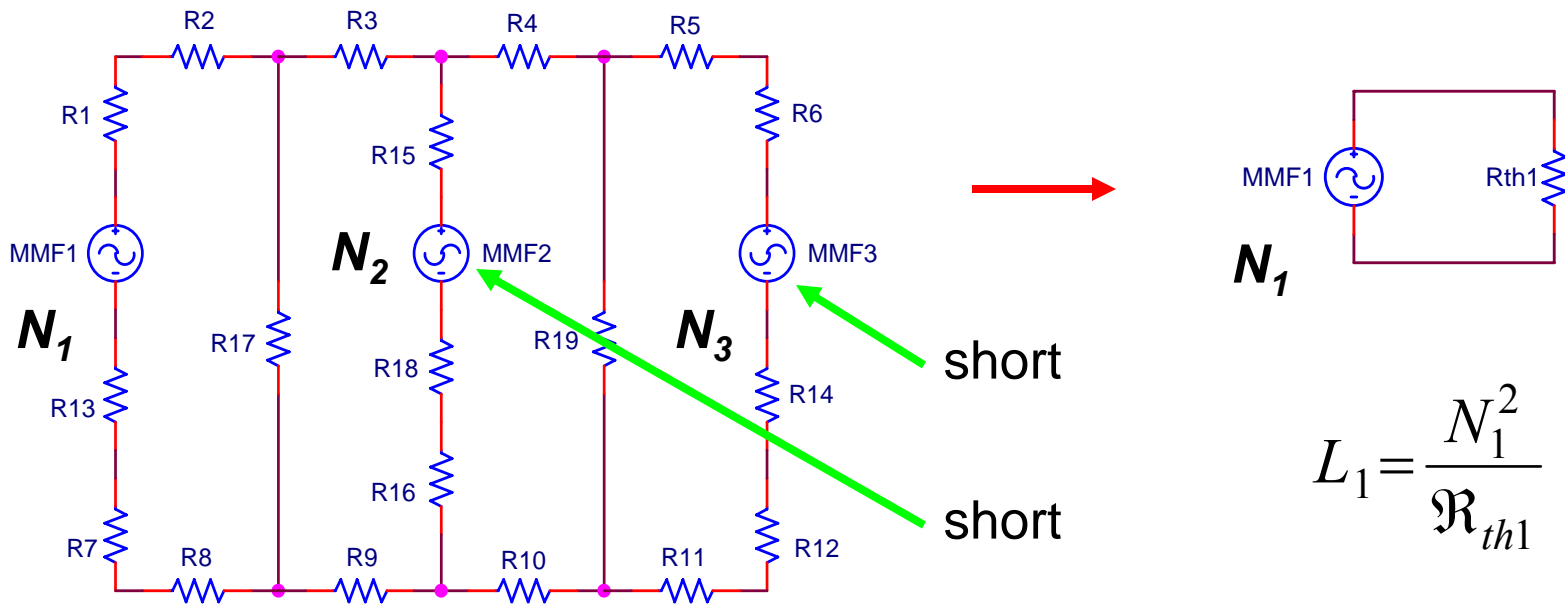

N_x = turns of winding x

$$L_1 = \frac{N_1^2}{\mathcal{R}_{th1}}$$



Leakage Inductances

- Replace the MMF source for each winding not being considered with a short circuit
- Replace the MMF source for the shorted winding with an open circuit
- Determine Thévenin equivalent reluctance, \mathcal{R}_{th} , at the MMF source for the winding where the leakage inductance is to be determined
- Inductance = turns squared divided by the Thévenin equivalent reluctance

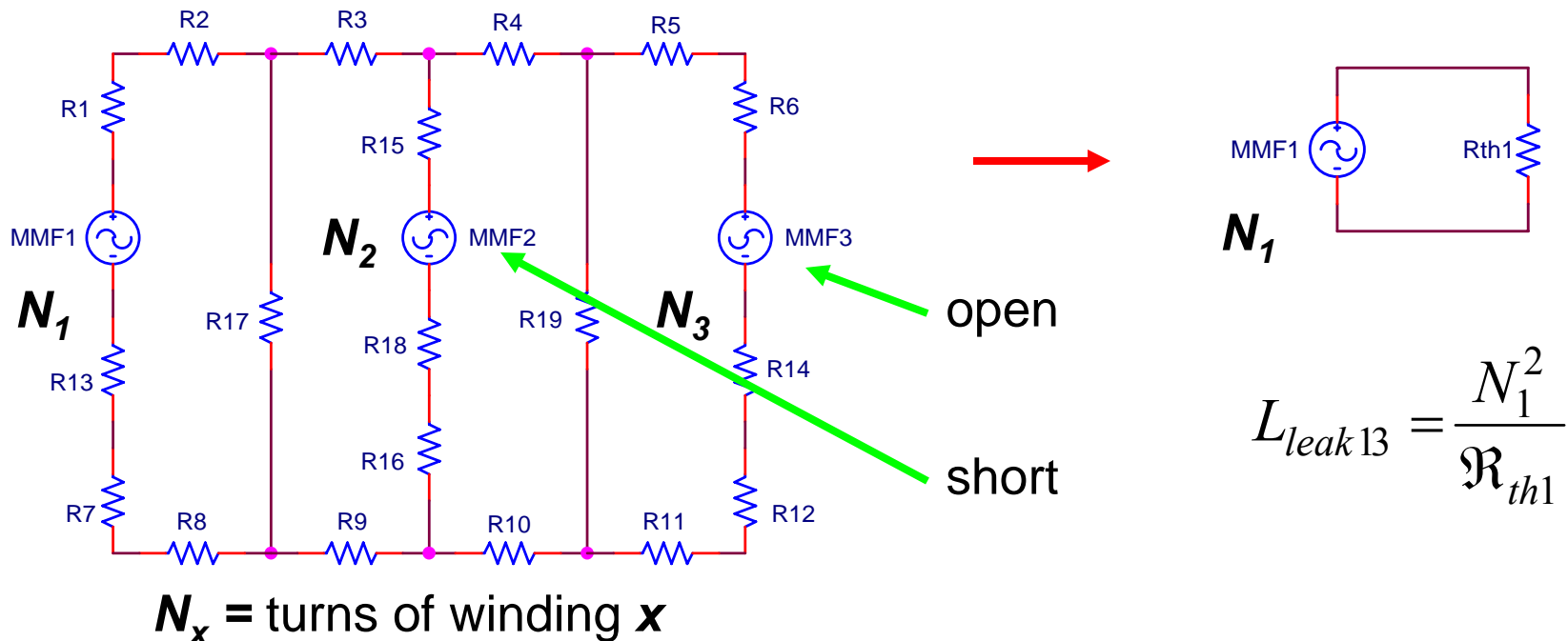

Reluctance Modeling References

- R. W. Erickson and D. Maksimovic, *Fundamentals of Power Electronics*, 2nd Ed., Norwell, MA: Kluwer Academic Publishers, 2001
- S.-A. El-Hamamsey and Eric I. Chang, “Magnetics Modeling for Computer-Aided Design of Power Electronics Circuits,” PESC 1989 Record, pp. 635-645
- G. W. Ludwig, and S.-A. El Hamamsy “Coupled Inductance and Reluctance Models of Magnetic Components,” IEEE Trans. on Power Electronics, Vol. 6, No. 2, April 1991, pp. 240-250
- E. Colin Cherry, “The Duality between Interlinked Electric and Magnetic Circuits and the Formation of Transformer Equivalent Circuits,” Proceedings of the Physical Society, vol. 62 part 2, section B, no. 350 B, Feb. 1949, pp. 101-111
- MIT Staff, *Magnetic Circuits and Transformers*. Cambridge, MA: MIT Press, 1943



Energy Storage

- The magnetic energy stored in one inductor is:

$$W_{M1} = \frac{1}{2} Li^2$$

- The energy stored in a set of N coupled windings is:

$$W_{MN} = \frac{1}{2} [i]^T [L] [i]$$

- The energy stored in a set of 2 coupled windings is:

$$W_{M2} = \frac{1}{2} \begin{bmatrix} i_1 & i_2 \end{bmatrix} \begin{bmatrix} L_{11} & L_{12} \\ L_{12} & L_{22} \end{bmatrix} \begin{bmatrix} i_1 \\ i_2 \end{bmatrix} = \frac{1}{2} (L_{11}i_1^2 + 2L_{12}i_1i_2 + L_{22}i_2^2)$$



Stability of a Set of Coupled Inductors

- As set of coupled inductors is passive if the magnetic energy storage is non-negative for any set of currents
- For two coupled inductors, this is guaranteed if: $-1 \leq k \leq 1$
- A set of three coupled inductors is passive if the following conditions are met:

$$k_{12}^2 + k_{23}^2 + k_{31}^2 - 2k_{12}k_{23}k_{31} \leq 1$$

$$-1 \leq k_{12} \leq 1 \quad -1 \leq k_{23} \leq 1 \quad -1 \leq k_{31} \leq 1$$

Yilmaz Tokad and Myril B. Reed, "Criteria and Tests for Realizability of the Inductance Matrix," Trans. AIEE, Part I, Communications and Electronics, Vol. 78, Jan. 1960, pp. 924-926



Stability of a Set of Coupled Inductors

- When there are more than three windings, the coupling coefficient matrix defined below can be used to determine stability

$$K = \begin{bmatrix} 1 & k_{12} & \cdots & k_{1N} \\ k_{21} & 1 & \cdots & k_{2N} \\ \vdots & \vdots & \ddots & \vdots \\ k_{N1} & k_{N2} & \cdots & 1 \end{bmatrix} \quad k_{qr} = k_{rq}$$

- A set of coupled inductors is passive if and only if all of the eigenvalues of K are non-negative
- There are N eigenvalues for a set of N windings
- Eigenvalue calculations are built-in functions of programs like Mathcad and Matlab



Consistency Checks

- The eigenvalue test can let you know if there are measurement errors, but it won't help identify the errors
- The ratios of magnetizing inductances on the same core leg should be approximately equal to the square of the turns ratios
- Set up test simulations to verify that the models match the test conditions
- Test leakage inductances by shorting one winding and applying a signal to the other winding (Compute the inductance indicated by the voltage, current and frequency)
- Check for coupling polarity errors, especially if there are windings on multiple core legs
- Compare test data with multiple windings shorted to simulations or calculations with multiple windings shorted



Inverse Inductance Matrix

- The inverse inductance matrix, Γ , is the reciprocal of the inductance matrix

$$\Gamma = L^{-1}$$

- Each diagonal element is equal to the reciprocal of the inductance of the corresponding winding when all of the other windings are shorted
- Example application: You have a four-winding transformer. What is the inductance at winding 1 when windings 3 and 4 are shorted?
- Set up an inductance matrix, L_x , by extracting all of the elements from the total inductance matrix that apply only to windings 1, 3 and 4



Inverse Inductance Matrix Example

- Remove the outlined elements from L to get L_x

$$L = \begin{bmatrix} L_{11} & L_{12} & L_{13} & L_{14} \\ L_{22} & L_{22} & L_{23} & L_{24} \\ L_{31} & L_{32} & L_{33} & L_{34} \\ L_{41} & L_{42} & L_{43} & L_{44} \end{bmatrix} \quad L_x = \begin{bmatrix} L_{11} & L_{13} & L_{14} \\ L_{31} & L_{33} & L_{34} \\ L_{41} & L_{43} & L_{44} \end{bmatrix}$$

- Use a computer program to compute the inverse of L_x

$$\Gamma_x = L_x^{-1}$$

- $\frac{1}{\Gamma_{x_{11}}}$ is the inductance at winding 1 when windings 3 and 4 are shorted



Modified Node Analysis

- Spice uses Modified Node Analysis (MNA) to set up the circuit equations
- This type of analysis is well suited for handling circuits with coupled windings

- A good description of the method is found in:

L. O. Chua, *Linear and Nonlinear Circuits*. New York: McGraw-Hill, 1987, pp. 469-472



Modified Node Analysis Example

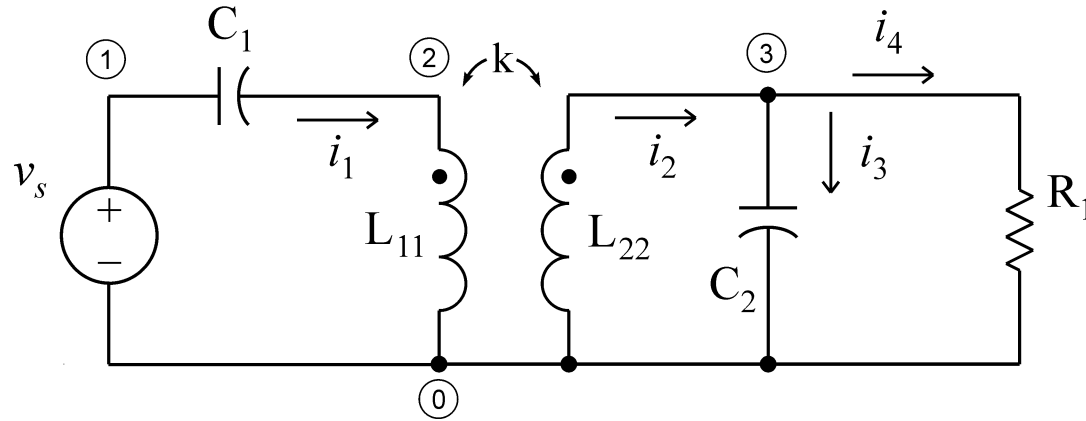

- Assign node numbers
- The reference node is node 0
- Assign currents for each branch
- Compute mutual inductances from the self inductances and coupling coefficients

$$L_{12} = k\sqrt{L_{11}L_{22}}$$



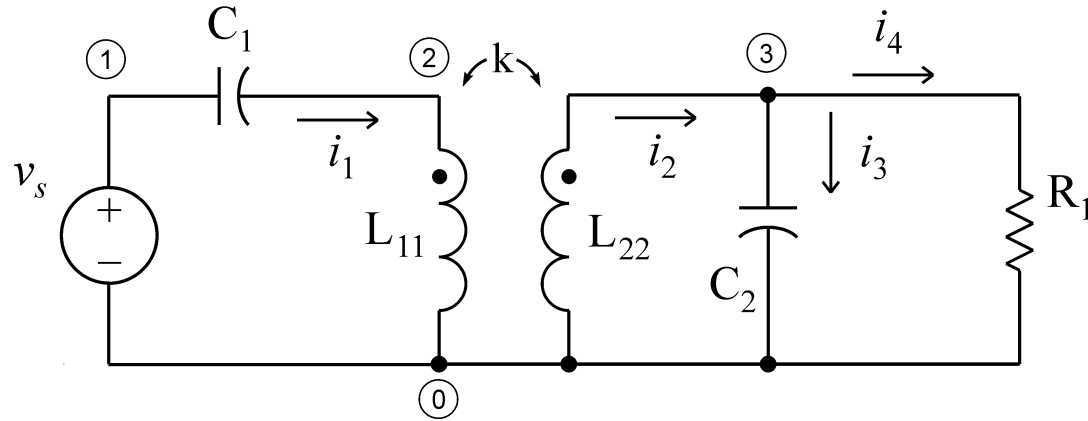

- Write a **KCL** equation using the node-to-datum voltages as variables for each node other than the datum node, unless the node has a fixed voltage with respect to the datum node. In that case, write an equation that assigns the node voltage to the fixed value.



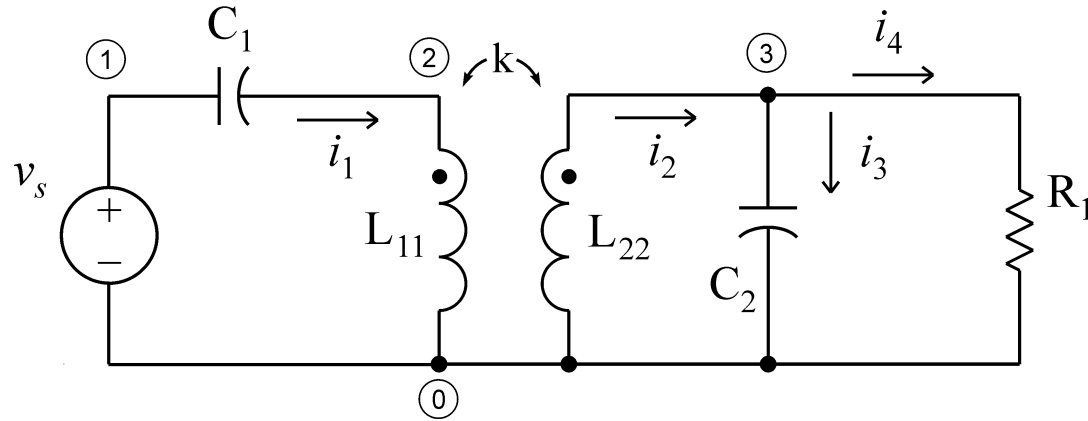

- Node 1 $v_1 = v_s$
- Node 2 $i_1 = j\omega C_1(v_1 - v_2) = j\omega C_1(v_s - v_2)$
- Node 3 $i_2 = \frac{v_3}{R_1} + j\omega C_2 v_3 = \left(\frac{1}{R_1} + j\omega C_2 \right) v_3$
- Current variables must be maintained for each coupled inductor
- Other current variables can be replaced by equivalent expressions



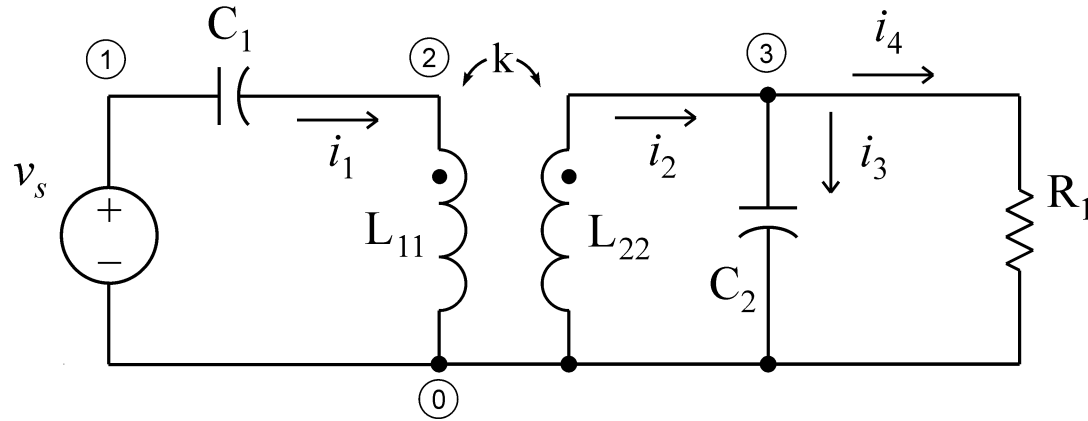

- Write an equation for the voltage dropped across each coupled inductor with the node variables on one side and the inductance and current terms on the other side

$$v_2 = j\omega L_{11}i_1 - j\omega L_{12}i_2$$

$$v_3 = j\omega L_{12}i_1 - j\omega L_{22}i_2$$

- Note that the minus signs are due to the fact that i_2 was assigned to be flowing out of the dotted end of the winding instead of into it



- Rearrange the node equations to facilitate writing matrix equations

$$i_1 = j\omega C_1(v_s - v_2) \quad \longrightarrow \quad v_2 + \frac{1}{j\omega C_1}i_1 = v_s$$

$$i_2 = \left(\frac{1}{R_1} + j\omega C_2 \right) v_3 \quad \longrightarrow \quad \left(\frac{1}{R_1} + j\omega C_2 \right) v_3 - i_2 = 0$$

$$v_2 = j\omega L_{11}i_1 - j\omega L_{12}i_2 \quad \longrightarrow \quad v_2 - j\omega L_{11}i_1 + j\omega L_{12}i_2 = 0$$

$$v_3 = j\omega L_{12}i_1 - j\omega L_{22}i_2 \quad \longrightarrow \quad v_3 - j\omega L_{12}i_1 + j\omega L_{22}i_2 = 0$$



- Convert the node equations into matrix form $G \cdot X = U$

$$\boxed{1} \quad v_2 + \frac{1}{j\omega C_1} i_1 = v_s$$

$$\boxed{2} \quad \left(\frac{1}{R_1} + j\omega C_2 \right) v_3 - i_2 = 0$$

$$\boxed{3} \quad v_2 - j\omega L_{11} i_1 + j\omega L_{12} i_2 = 0$$

$$\boxed{4} \quad v_3 - j\omega L_{12} i_1 + j\omega L_{22} i_2 = 0$$

$$\begin{array}{l} \boxed{1} \\ \boxed{2} \\ \boxed{3} \\ \boxed{4} \end{array} \begin{bmatrix} 1 & 0 & \frac{1}{j\omega C_1} & 0 \\ 0 & \left(\frac{1}{R_1} + j\omega C_2 \right) & 0 & -1 \\ 1 & 0 & -j\omega L_{11} & j\omega L_{12} \\ 0 & 1 & -j\omega L_{12} & j\omega L_{22} \end{bmatrix} \cdot \begin{bmatrix} v_2 \\ v_3 \\ i_1 \\ i_2 \end{bmatrix} = \begin{bmatrix} v_s \\ 0 \\ 0 \\ 0 \end{bmatrix}$$



Modified Node Analysis Example Conclusions

- The matrix equation can be solved numerically in programs like Mathcad or Matlab
- The approach is straightforward and can be used with many windings
- If you want to have a symbolic solution, simple cases can be handled with equivalent circuits (the cantilever model is easiest for two windings)
- Equivalent circuit equations can get very messy with more than two windings
- Is there a better way to find symbolic solutions by using Dr. R. D. Middlebrook's Design-Oriented Analysis techniques? (I hope to find out)

See Dr. Middlebrook's web site: www.ardem.com for information on his analysis techniques



Coupling Stability Example Using Mathcad

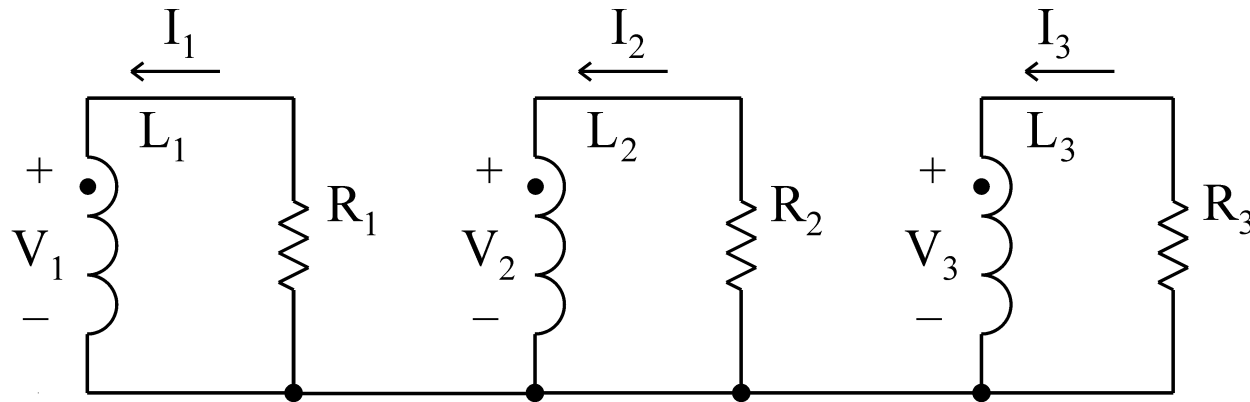

Figure 1. Three coupled windings with resistive loads.

Suppose we have a three-winding inductor with a resistor terminating each winding as is shown in Fig. 1. If we externally force an initial condition of currents in the windings, and then let the inductor "coast" on its own, the currents should all exponentially decay to zero as the stored energy is dissipated.

If the coupling coefficient matrix is not positive definite, however, at least one of the eigenvalues for the system will be not be negative.



As is shown below, this produces an unstable situation where more energy can be extracted from the inductor than was initially stored there.

When the initial energy is dissipated, the stored energy becomes negative, and the inductor continues to deliver power. This, of course, is impossible. Therefore, a set of coupling coefficients in which the coupling coefficient matrix is not positive definite describes a coupled inductor that is not physically realizable.

Because Spice and other circuit simulators allow such inductors to be specified, it is instructive to examine what happens when nonphysical sets of coupling coefficients are specified.



We first examine a physically-realizable case. After that, we show what happens when the coupling coefficients are improperly chosen.

Enter the values of the inductances and coupling coefficients

$$L_1 := 10 \cdot \mu\text{H}$$

$$k_{12} := 0.96$$

$$L_2 := 11 \cdot \mu\text{H}$$

$$k_{23} := 0.99$$

$$L_3 := 10 \cdot \mu\text{H}$$

$$k_{13} := 0.98$$



Construct the coupling coefficient matrix.

$$\mathbf{K} := \begin{pmatrix} 1 & k_{12} & k_{13} \\ k_{12} & 1 & k_{23} \\ k_{13} & k_{23} & 1 \end{pmatrix}$$

Compute the eigenvalues of the coupling coefficient matrix.

$$\text{eigenvals}(\mathbf{K}) = \begin{pmatrix} 2.953 \\ 0.041 \\ 5.654 \times 10^{-3} \end{pmatrix}$$

All of the eigenvalues are positive. As is shown below, this leads to negative eigenvalues for the time response of the system.



Construct the inductance matrix.

$$L := \begin{pmatrix} L_1 & K_{1,2} \cdot \sqrt{L_1 \cdot L_2} & K_{1,3} \cdot \sqrt{L_1 \cdot L_3} \\ K_{1,2} \cdot \sqrt{L_1 \cdot L_2} & L_2 & K_{2,3} \cdot \sqrt{L_2 \cdot L_3} \\ K_{1,3} \cdot \sqrt{L_1 \cdot L_3} & K_{2,3} \cdot \sqrt{L_2 \cdot L_3} & L_3 \end{pmatrix}$$

Evaluate the inductance matrix.

$$L = \begin{pmatrix} 10.000 & 10.069 & 9.800 \\ 10.069 & 11.000 & 10.383 \\ 9.800 & 10.383 & 10.000 \end{pmatrix} \mu\text{H}$$

Enter the values of the resistances

$$R_1 := 1 \cdot \Omega$$

$$R_2 := 1 \cdot \Omega$$

$$R_3 := 1 \cdot \Omega$$



Enter the initial values of the currents

$$I_{1i} := 1 \cdot A$$

$$I_{2i} := 0 \cdot A$$

$$I_{3i} := 0 \cdot A$$

Define a current vector

$$I = \begin{pmatrix} I_1 \\ I_2 \\ I_3 \end{pmatrix}$$

Define an initial condition vector

$$I_i := \begin{pmatrix} I_{1i} \\ I_{2i} \\ I_{3i} \end{pmatrix}$$

$$I_i = \begin{pmatrix} 1 \\ 0 \\ 0 \end{pmatrix} A$$

We can think of this as a situation in which the current in winding 1 is externally forced to be 1 Ampere, and then the circuit is left to dissipate the stored energy starting at time $t = 0$.



Compute the stored energy $I_i^T \cdot L \cdot I_i = 1.000 \times 10^{-5} \text{ J}$

The time response of the circuit of Fig. 1 can be described by the following equation

$$\begin{pmatrix} -I_1 \cdot R_1 \\ -I_2 \cdot R_2 \\ -I_3 \cdot R_3 \end{pmatrix} = L \cdot \frac{d}{dt} I \quad (1)$$

Compute the inverse inductance matrix $\Gamma := L^{-1}$

$$\Gamma = \begin{pmatrix} 2.909 & 1.422 & -4.327 \\ 1.422 & 5.263 & -6.858 \\ -4.327 & -6.858 & 11.462 \end{pmatrix} \frac{1}{\mu\text{H}}$$

Compute the eigenvalues of Γ .

$$\text{eigenvals}(\Gamma) = \begin{pmatrix} 17.251 \\ 2.351 \\ 0.033 \end{pmatrix} \frac{1}{\mu\text{H}}$$

Write (1) in terms of the inverse inductance matrix

$$\frac{d}{dt} \mathbf{I} = \Gamma \cdot \begin{pmatrix} -I_1 \cdot R_1 \\ -I_2 \cdot R_2 \\ -I_3 \cdot R_3 \end{pmatrix} \quad (2)$$

Write (2) in a way that shows \mathbf{I} in the right side

$$\frac{d}{dt} \mathbf{I} = \Gamma \cdot \begin{pmatrix} -R_1 & 0 & 0 \\ 0 & -R_2 & 0 \\ 0 & 0 & -R_3 \end{pmatrix} \cdot \mathbf{I} \quad (3)$$



Define G

$$G := \Gamma \cdot \begin{pmatrix} -R_1 & 0 & 0 \\ 0 & -R_2 & 0 \\ 0 & 0 & -R_3 \end{pmatrix} \quad (4)$$

Substitute G into (3)

$$\frac{d}{dt} I = G \cdot I \quad (5)$$

Compute the eigenvalues of G

$$\lambda := \text{eigenvals}(G) \quad \lambda = \begin{pmatrix} -1.725 \times 10^7 \\ -2.351 \times 10^6 \\ -3.277 \times 10^4 \end{pmatrix} \text{s}^{-1}$$



Compute the eigenvectors of G

$$\Lambda := \text{eigenvecs}(G) \quad \Lambda = \begin{pmatrix} 0.295 & 0.77 & 0.565 \\ 0.501 & -0.628 & 0.595 \\ -0.814 & -0.107 & 0.571 \end{pmatrix} \text{s}^{-1}$$

The solution to (5) will have the form

$$I = \Lambda \cdot \begin{pmatrix} c_1 & 0 & 0 \\ 0 & c_2 & 0 \\ 0 & 0 & c_3 \end{pmatrix} \cdot \begin{pmatrix} e^{\lambda_1 \cdot t} \\ e^{\lambda_2 \cdot t} \\ e^{\lambda_3 \cdot t} \end{pmatrix} \quad (6)$$



The values of the constants c_1 , c_2 and c_3 can be determined from the initial conditions

$$I_0 = \Lambda \cdot \begin{pmatrix} c_1 \\ c_2 \\ c_3 \end{pmatrix} \quad \begin{pmatrix} c_1 \\ c_2 \\ c_3 \end{pmatrix} := \Lambda^{-1} \cdot I_i \quad \begin{pmatrix} c_1 \\ c_2 \\ c_3 \end{pmatrix} = \begin{pmatrix} 0.295 \\ 0.77 \\ 0.565 \end{pmatrix} \text{ A} \cdot \text{s}$$

Check to see if the initial conditions are satisfied

$$\Lambda \cdot \begin{pmatrix} c_1 \\ c_2 \\ c_3 \end{pmatrix} = \begin{pmatrix} 1 \\ 0 \\ 0 \end{pmatrix} \text{ A} \quad I_i = \begin{pmatrix} 1 \\ 0 \\ 0 \end{pmatrix} \text{ A}$$



Compute a coefficient matrix

$$C := \Lambda \cdot \begin{pmatrix} c_1 & 0 & 0 \\ 0 & c_2 & 0 \\ 0 & 0 & c_3 \end{pmatrix} \quad C = \begin{pmatrix} 0.087 & 0.594 & 0.319 \\ 0.148 & -0.484 & 0.336 \\ -0.24 & -0.083 & 0.323 \end{pmatrix} A$$

(Note that the minimum index value for matrices in this document is set at 1, not zero.)

Define current functions

$$I_1(t) := C_{1,1} \cdot e^{\lambda_1 \cdot t} + C_{1,2} \cdot e^{\lambda_2 \cdot t} + C_{1,3} \cdot e^{\lambda_3 \cdot t}$$

$$I_2(t) := C_{2,1} \cdot e^{\lambda_1 \cdot t} + C_{2,2} \cdot e^{\lambda_2 \cdot t} + C_{2,3} \cdot e^{\lambda_3 \cdot t}$$

$$I_3(t) := C_{3,1} \cdot e^{\lambda_1 \cdot t} + C_{3,2} \cdot e^{\lambda_2 \cdot t} + C_{3,3} \cdot e^{\lambda_3 \cdot t}$$



Check the current values at a few points

$$I_1(0 \cdot s) = 1 \text{ A}$$

$$I_1(0.1 \cdot \mu\text{s}) = 0.803 \text{ A}$$

$$I_1(10 \cdot \mu\text{s}) = 0.23 \text{ A}$$

$$I_2(0) = 0 \text{ A}$$

$$I_2(0.1 \cdot \mu\text{s}) = -0.021 \text{ A}$$

$$I_2(10 \cdot \mu\text{s}) = 0.242 \text{ A}$$

$$I_3(0) = 0 \text{ A}$$

$$I_3(0.1 \cdot \mu\text{s}) = 0.214 \text{ A}$$

$$I_3(10 \cdot \mu\text{s}) = 0.233 \text{ A}$$



Plot the current values $t := 0, 10^{-9} \cdot s .. 20 \cdot 10^{-7} \cdot s$

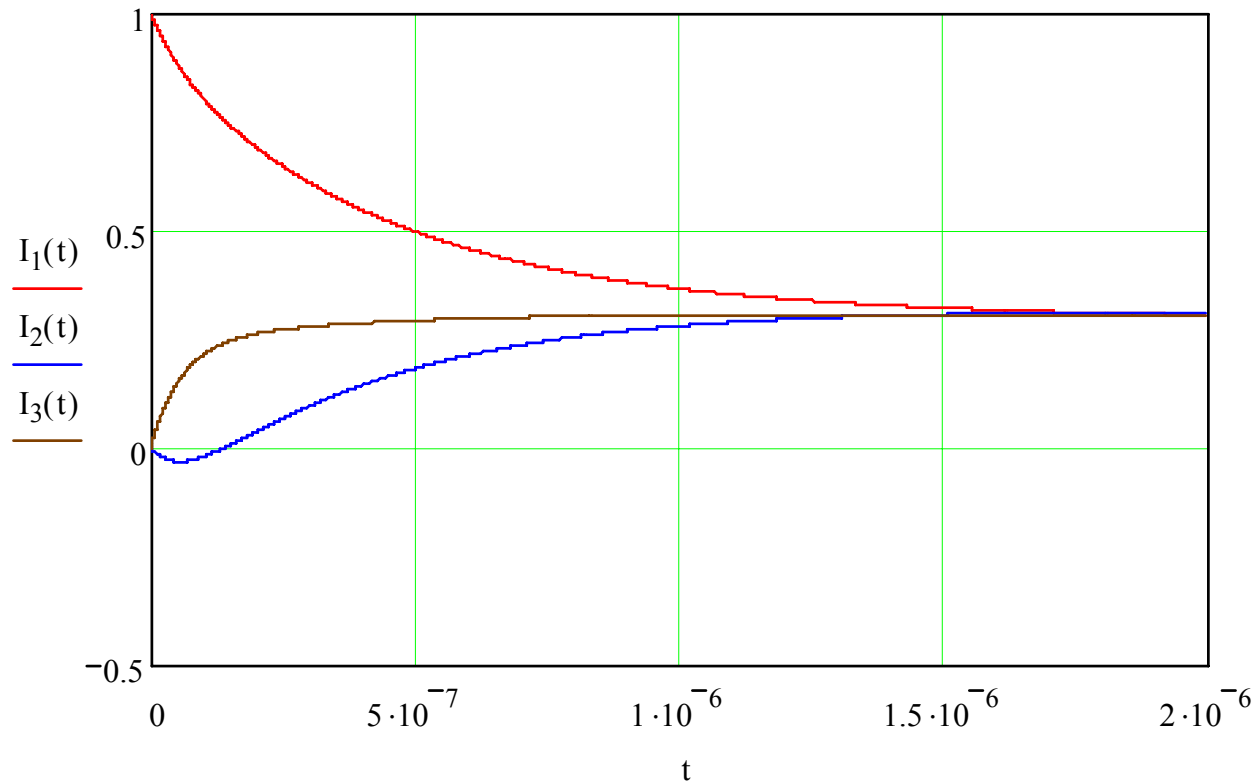

Fig. 2. Winding Currents.

I_1 drops quickly as the current builds up in the other two windings. All of the currents then decay.



Define a current vector to facilitate calculating the stored energy.

$$\mathbf{I}(t) := \begin{pmatrix} I_1(t) \\ I_2(t) \\ I_3(t) \end{pmatrix}$$

Define a function to compute the stored energy.

$$W(t) := \frac{1}{2} \cdot (\mathbf{I}(t))^T \cdot \mathbf{L} \cdot \mathbf{I}(t)$$



$$t := 0, 10^{-7} \cdot s .. 10^{-5} \cdot s$$

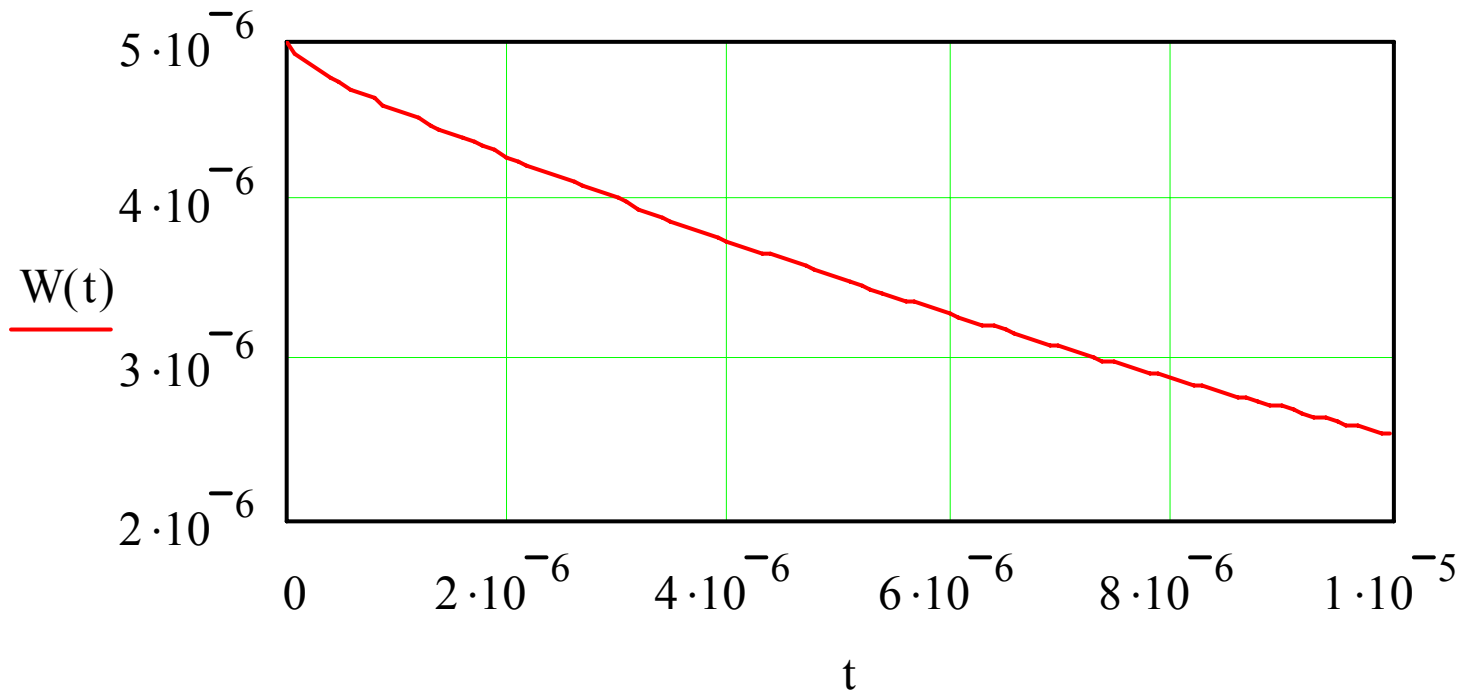

Fig. 3. Stored energy, J.

The stored energy is dissipated as expected.



We can now examine a case where the coupling coefficient are improperly specified. A relatively small change in one of the couple coefficients is all that is required to create an unstable configuration.

Enter the values of the inductances and coupling coefficients

$$L_1 := 10 \cdot \mu\text{H}$$

$$k_{12} := 0.96$$

$$L_2 := 11 \cdot \mu\text{H}$$

$$k_{23} := 0.99$$

$$L_3 := 10 \cdot \mu\text{H}$$

$$k_{13} := 0.99$$

(Previously 0.98)



Construct the coupling coefficient matrix.

$$K := \begin{pmatrix} 1 & k_{12} & k_{13} \\ k_{12} & 1 & k_{23} \\ k_{13} & k_{23} & 1 \end{pmatrix}$$

Compute the eigenvalues of the coupling coefficient matrix.

$$\text{eigenvals}(K) = \begin{pmatrix} 2.96 \\ 0.04 \\ -6.757 \times 10^{-5} \end{pmatrix}$$

One of the eigenvalues is negative. As is shown below on, this makes one of the eigenvalues for the time response of the system positive.



Construct the inductance matrix.

$$L := \begin{pmatrix} L_1 & K_{1,2} \cdot \sqrt{L_1 \cdot L_2} & K_{1,3} \cdot \sqrt{L_1 \cdot L_3} \\ K_{1,2} \cdot \sqrt{L_1 \cdot L_2} & L_2 & K_{2,3} \cdot \sqrt{L_2 \cdot L_3} \\ K_{1,3} \cdot \sqrt{L_1 \cdot L_3} & K_{2,3} \cdot \sqrt{L_2 \cdot L_3} & L_3 \end{pmatrix}$$

Evaluate the inductance matrix.

$$L = \begin{pmatrix} 10.000 & 10.069 & 9.900 \\ 10.069 & 11.000 & 10.383 \\ 9.900 & 10.383 & 10.000 \end{pmatrix} \mu\text{H}$$

Enter the values of the resistances

$$R_1 := 1 \cdot \Omega$$

$$R_2 := 1 \cdot \Omega$$

$$R_3 := 1 \cdot \Omega$$



Enter the initial values of the currents

$$I_{1i} := 1 \cdot \text{A} \quad I_{2i} := 0 \cdot \text{A} \quad I_{3i} := 0 \cdot \text{A}$$

Define an initial condition vector

$$I_i := \begin{pmatrix} I_{1i} \\ I_{2i} \\ I_{3i} \end{pmatrix} \quad I_i = \begin{pmatrix} 1 \\ 0 \\ 0 \end{pmatrix} \text{A}$$

Compute the stored energy

$$I_i^T \cdot L \cdot I_i = 1.000 \times 10^{-5} \text{ J}$$



Compute the inverse inductance matrix

$$\Gamma := \mathbf{L}^{-1}$$

$$\Gamma = \begin{pmatrix} -248.75 & -239.557 & 495 \\ -239.557 & -226.136 & 471.964 \\ 495 & 471.964 & -980 \end{pmatrix} \frac{1}{\mu\text{H}}$$

Compute the eigenvalues of Γ .

$$\text{eigenvals}(\Gamma) = \begin{pmatrix} -1.457 \times 10^3 \\ 2.385 \\ 0.033 \end{pmatrix} \frac{1}{\mu\text{H}}$$



Define G

$$G := \Gamma \cdot \begin{pmatrix} -R_1 & 0 & 0 \\ 0 & -R_2 & 0 \\ 0 & 0 & -R_3 \end{pmatrix} \quad (4)$$

Compute the eigenvalues of G $\lambda := \text{eigenvals}(G)$

$$\lambda = \begin{pmatrix} 1.457 \times 10^9 \\ -2.385 \times 10^6 \\ -3.27 \times 10^4 \end{pmatrix} \text{s}^{-1}$$

One of the eigenvalues is positive, so the system is unstable.



Compute the eigenvectors of G

$$\Lambda := \text{eigenvecs}(G) \quad \Lambda = \begin{pmatrix} -0.414 & -0.713 & 0.566 \\ -0.395 & 0.701 & 0.594 \\ 0.82 & -0.023 & 0.572 \end{pmatrix} \text{s}^{-1}$$

The solution to (5) will have the form

$$I = \Lambda \cdot \begin{pmatrix} c_1 & 0 & 0 \\ 0 & c_2 & 0 \\ 0 & 0 & c_3 \end{pmatrix} \cdot \begin{pmatrix} e^{\lambda_1 \cdot t} \\ e^{\lambda_2 \cdot t} \\ e^{\lambda_3 \cdot t} \end{pmatrix} \quad (6)$$



The values of the constants c_1 , c_2 and c_3 can be determined from the initial conditions

$$I_0 = \Lambda \cdot \begin{pmatrix} c_1 \\ c_2 \\ c_3 \end{pmatrix} \quad \begin{pmatrix} c_1 \\ c_2 \\ c_3 \end{pmatrix} := \Lambda^{-1} \cdot I_i \quad \begin{pmatrix} c_1 \\ c_2 \\ c_3 \end{pmatrix} = \begin{pmatrix} -0.414 \\ -0.713 \\ 0.566 \end{pmatrix} \text{ A} \cdot \text{s}$$

Check to see if the initial conditions are satisfied

$$\Lambda \cdot \begin{pmatrix} c_1 \\ c_2 \\ c_3 \end{pmatrix} = \begin{pmatrix} 1 \\ 0 \\ 0 \end{pmatrix} \text{ A} \quad I_i = \begin{pmatrix} 1 \\ 0 \\ 0 \end{pmatrix} \text{ A}$$



Compute a coefficient matrix

$$C := \Lambda \cdot \begin{pmatrix} c_1 & 0 & 0 \\ 0 & c_2 & 0 \\ 0 & 0 & c_3 \end{pmatrix} \quad C = \begin{pmatrix} 0.172 & 0.508 & 0.32 \\ 0.164 & -0.5 & 0.336 \\ -0.34 & 0.016 & 0.323 \end{pmatrix} A$$

Define current functions

$$I_1(t) := C_{1,1} \cdot e^{\lambda_1 \cdot t} + C_{1,2} \cdot e^{\lambda_2 \cdot t} + C_{1,3} \cdot e^{\lambda_3 \cdot t}$$

$$I_2(t) := C_{2,1} \cdot e^{\lambda_1 \cdot t} + C_{2,2} \cdot e^{\lambda_2 \cdot t} + C_{2,3} \cdot e^{\lambda_3 \cdot t}$$

$$I_3(t) := C_{3,1} \cdot e^{\lambda_1 \cdot t} + C_{3,2} \cdot e^{\lambda_2 \cdot t} + C_{3,3} \cdot e^{\lambda_3 \cdot t}$$



Check the current values at a few points

$I_1(0 \cdot s) = 1 \text{ A}$	$I_1(0.01 \cdot \mu\text{s}) = 4 \times 10^5 \text{ A}$	$I_1(0.1 \cdot \mu\text{s}) = 3.344 \times 10^{62} \text{ A}$
$I_2(0 \cdot s) = 0 \text{ A}$	$I_2(0.01 \cdot \mu\text{s}) = 3 \times 10^5 \text{ A}$	$I_2(0.1 \cdot \mu\text{s}) = 3.189 \times 10^{62} \text{ A}$
$I_3(0 \cdot s) = 0 \text{ A}$	$I_3(0.01 \cdot \mu\text{s}) = -7 \times 10^5 \text{ A}$	$I_3(0.1 \cdot \mu\text{s}) = -6.621 \times 10^{62} \text{ A}$



Plot the current values $t := 0, 10^{-11} \cdot s .. 4.2 \cdot 10^{-9} \cdot s$

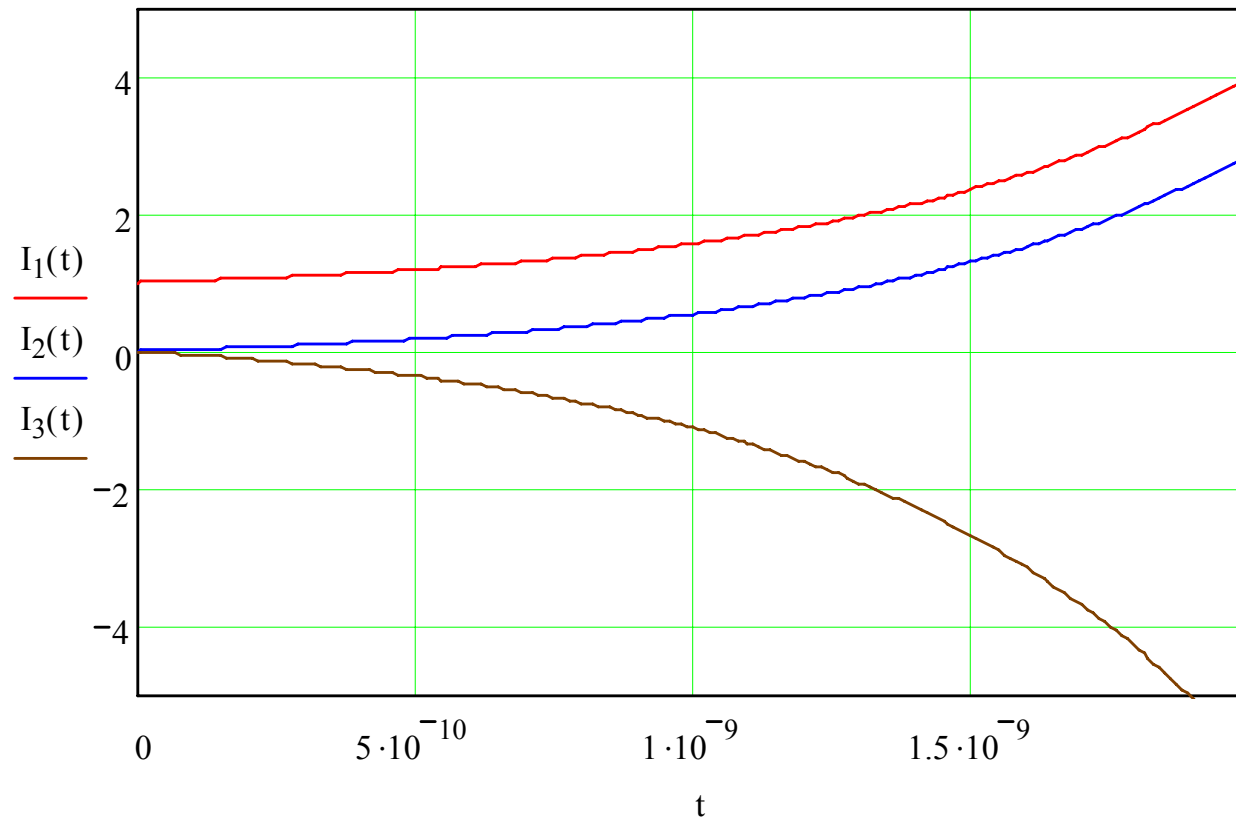

Fig. 4. Winding Currents.

I_1 rises instead of decaying. The other currents start at zero and then build up.



Define a current vector to facilitate calculating the stored energy.

$$\mathbf{I}(t) := \begin{pmatrix} I_1(t) \\ I_2(t) \\ I_3(t) \end{pmatrix}$$

Define a function to compute the stored energy.

$$W(t) := \frac{1}{2} \cdot (\mathbf{I}(t))^T \cdot \mathbf{L} \cdot \mathbf{I}(t)$$



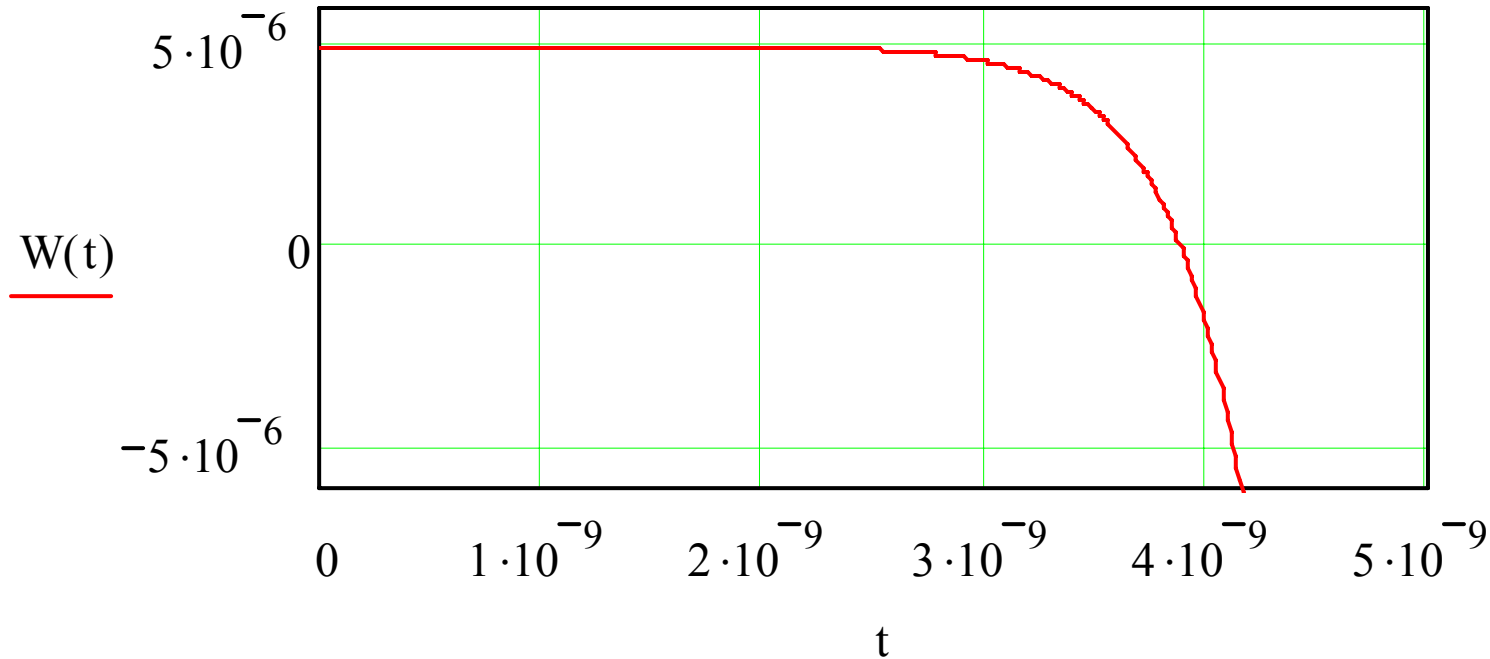

Fig. 5. Stored energy.

The stored energy decays to zero, but it then goes negative as our imaginary inductor pumps out energy at a rapidly-increasing rate.

One of the things that we can learn from this example is that estimating values for coupling coefficients can easily produce a nonphysical circuit. Trying to simulate such a circuit may produce frustration as one tries to figure out why the circuit won't converge.



Acknowledgement

- Thanks to my manager, Dr. David J. Christie, for reviewing the presentation and providing helpful comments and suggestions
- Also, thanks to Dr. James H. Spreen for his continuing guidance





Better technology. Better results.

NASDAQ: AEIS

www.advanced-energy.com